

# TEST REPORT



## CTK Co., Ltd.

5 Dongbu-ro 221beon-gil, Cheoin-gu, Yongin-si,  
Gyeonggi-do, Republic of Korea  
Tel: +82-31-339-9970  
Fax: +82-31-624-9501

REPORT No.:  
CTK-2026-00010  
Page (1) / (12) pages

### 1. Applicant

- Name : Hanwha Vision Co., Ltd
- Address : 6, Pangyo-ro 319Beon-gil, Bundang-gu, Seongnam-si, Gyeonggi-do, 13488 Republic of Korea
- Date of Receipt : Nov. 17, 2025

### 2. Manufacturer

- Name : Hanwha Vision Co., Ltd

### 3. Use of Report :

For submission to customer

### 4. Test sample / Model :

NETWORK CAMERA / XNV-A9016R

### 5. Date(s) of test :

Dec 05, 2025

### 6. Test Standard (Method) used :

IEC 62262:2002+AMD1:2021

### 7. Testing Environment :

Temperature: (25 ±10) °C, Humidity: (50 ±25) % R.H.

Pressure: (96 ±10) kPa

### 8. Test Results :

Refer to the test results

### 9. Location of Test :

Permanent Testing Lab  On Site Testing  
(5 Dongbu-ro 221beon-gil, Cheoin-gu, Yongin-si, Gyeonggi-do, Republic of Korea)

The results shown in this test report refer only to the sample(s) tested unless otherwise stated. This report cannot be reproduced or copied without the written consent of CTK.

Approval	Tested by	Technical Manager
	Name: HyungUk Jeon (Signature)	Name: HoHyun Lee (Signature)

Remark. This report is not related to KOLAS accreditation and relevant regulation.

Jan. 02, 2025

CTK Co., Ltd.



**CTK Co., Ltd.**

5 Dongbu-ro 221beon-gil, Cheoin-gu, Yongin-si,  
Gyeonggi-do, Republic of Korea  
Tel: +82-31-339-9970  
Fax: +82-31-624-9501

REPORT No.:  
CTK-2026-00010  
Page (2) / (12) pages

## Table of Contents

1. Testing laboratory _____	3
1.1 Testing laboratory information .....	3
1.2 Testing laboratory accreditation status .....	3
2. Product description and equipment information _____	4
2.1 Product description .....	4
2.2 Equipment information .....	4
2.3 Pre-test product images .....	5
2.4 Testing equipment images .....	6
3. Degrees of protection provided by enclosures for electrical equipment against external mechanical impacts (IK code) _____	7
3.1 Test date and environmental conditions .....	7
3.2 Test condition .....	7
3.3 Testing images .....	8
3.4 Test result .....	9
3.5 Post-test product images and hit area images .....	10
3.6 Enclosure Dimensions or Impact point .....	12

**CTK Co., Ltd.**

5 Dongbu-ro 221beon-gil, Cheoin-gu, Yongin-si,  
Gyeonggi-do, Republic of Korea  
Tel: +82-31-339-9970  
Fax: +82-31-624-9501

REPORT No.:  
CTK-2026-00010  
Page (3) / (12) pages

## 1. Testing laboratory

### 1.1 Testing laboratory information

Lab. Name	CTK Co., Ltd.
Representative	Young Joseph Seungwon
Address	5 Dongbu-ro 221beon-gil, Cheoin-gu, Yongin-si, Gyeonggi-do, Republic of Korea
Tel.	+82-31-339-9970
Fax.	+82-31-624-9501
E-Mail	<a href="mailto:all.youngjin@element.com">all.youngjin@element.com</a>
Website	<a href="http://www.elementkorea.kr">www.elementkorea.kr</a>

### 1.2 Testing laboratory accreditation status

Country	Classification	Accreditation Number	Logo
International	KOLAS	TESTING NO. KT119	

**CTK Co., Ltd.**

5 Dongbu-ro 221beon-gil, Cheoin-gu, Yongin-si,  
Gyeonggi-do, Republic of Korea  
Tel: +82-31-339-9970  
Fax: +82-31-624-9501

REPORT No.:  
CTK-2026-00010  
Page (4) / (12) pages

## 2. Product description and equipment information

### 2.1 Product description

Product Name	Model Name	Quantity	Comment
NETWORK CAMERA	XNV-A9016R	1 EA	-

### 2.2 Model description

Basic Model .....	XNV-A9016R
Series model .....	XNV-A8016R,XNV-A6016R
Model differences .....	Use of the same external shape and materials (case, finishing material, PCB, cable, etc.), Image sensor and Lens difference.

### 2.3 Equipment information

Testing equipment	Model Name	Manufacturer	Manufacturing Number	Next Cal. Date
Vertical Hammer Tester	Vertical Hammer	Kingpo	0190605A01002	-
Vertical Hammer	5000g	Kingpo	TX-029-20J	Jul. 08, 2026
Steel measuring meter	5.5 m	KOMELON	225851	Jan. 16, 2026



## CTK Co., Ltd.

5 Dongbu-ro 221beon-gil, Cheoin-gu, Yongin-si,  
Gyeonggi-do, Republic of Korea  
Tel: +82-31-339-9970  
Fax: +82-31-624-9501

REPORT No.:  
CTK-2026-00010  
Page (5) / (12) pages

## 2.4 Pre-test product images

### 2.4.1 Test sample #1



Top



Bottom



Front



Rear



Left side



Right side



## CTK Co., Ltd.

5 Dongbu-ro 221beon-gil, Cheoin-gu, Yongin-si,  
Gyeonggi-do, Republic of Korea  
Tel: +82-31-339-9970  
Fax: +82-31-624-9501

REPORT No.:  
CTK-2026-00010  
Page (6) / (12) pages

## 2.5 Testing equipment images

### 2.5.1 Test equipment (1)

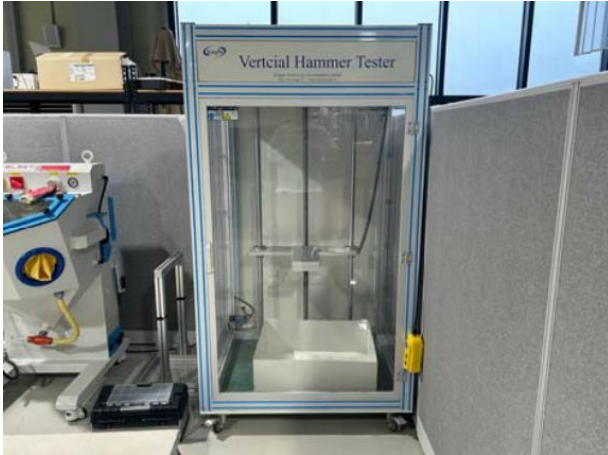

Vertical Hammer Tester



Vertical Hammer



Steel measuring meter

**CTK Co., Ltd.**

5 Dongbu-ro 221beon-gil, Cheoin-gu, Yongin-si,  
Gyeonggi-do, Republic of Korea  
Tel: +82-31-339-9970  
Fax: +82-31-624-9501

REPORT No.:  
CTK-2026-00010  
Page (7) / (12) pages

### 3. Degrees of protection provided by enclosures for electrical equipment against external mechanical impacts (IK code)

#### 3.1 Test date and environmental conditions

3.1.1 Test date: Dec 05, 2025

3.1.2 Measured Environmental Conditions

Item	Temperature (°C)	Humidity (% R.H.)	Pressure (kPa)
Measurement	25.1	60.7	101.2

#### 3.2 Test condition

3.2.1 Test standard: IEC 62262:2002+AMD1:2021

3.2.2 Sample status: Non-operation

IK code	Impact Energy (J)	Equivalent mass (kg)	Drop height (mm ± 1%)	Application
00	Non-protected	-	-	<input type="checkbox"/>
01	0.14	0.25	56	<input type="checkbox"/>
02	0.20	0.25	80	<input type="checkbox"/>
03	0.35	0.25	140	<input type="checkbox"/>
04	0.50	0.25	200	<input type="checkbox"/>
05	0.70	0.25	280	<input type="checkbox"/>
06	1.00	0.25	400	<input type="checkbox"/>
07	2.00	0.50	400	<input type="checkbox"/>
08	5.00	1.70	300	<input type="checkbox"/>
09	10.00	5.00	200	<input type="checkbox"/>
10	20.00	5.00	400	<input checked="" type="checkbox"/>
11	50.00	10.00	500	<input type="checkbox"/>

Impact times: five times for each of the exposed surface. (Do not impact more than 3 times in the same spot)



### CTK Co., Ltd.

5 Dongbu-ro 221beon-gil, Cheoin-gu, Yongin-si,  
Gyeonggi-do, Republic of Korea  
Tel: +82-31-339-9970  
Fax: +82-31-624-9501

REPORT No.:  
CTK-2026-00010  
Page (8) / (12) pages

## 3.3 Testing images

### 3.3.1 Evidence of test setting (1)



**CTK Co., Ltd.**

5 Dongbu-ro 221beon-gil, Cheoin-gu, Yongin-si,  
Gyeonggi-do, Republic of Korea  
Tel: +82-31-339-9970  
Fax: +82-31-624-9501

REPORT No.:  
CTK-2026-00010  
Page (9) / (12) pages

**3.4 Test result**

## 3.4.1 Test result table

Evaluation Criteria	Test Results	Remark
Visual Inspection	Some scratches were generated on the outside of the product.	-

※ Refer to the product photos after the completion of testing in section 3.5.2



## CTK Co., Ltd.

5 Dongbu-ro 221beon-gil, Cheoin-gu, Yongin-si,  
Gyeonggi-do, Republic of Korea  
Tel: +82-31-339-9970  
Fax: +82-31-624-9501

REPORT No.:  
CTK-2026-00010  
Page (10) / (12) pages

### 3.5 Post-test product images and hit area images

#### 3.5.1 Check the hit area during the test



Check the hit area the test\_1

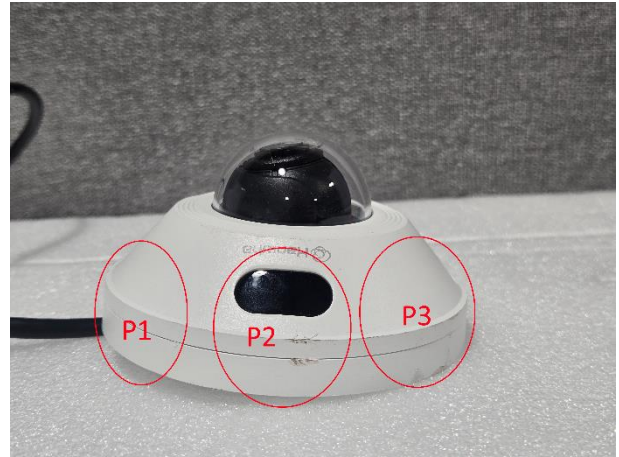

Check the hit area the test\_2

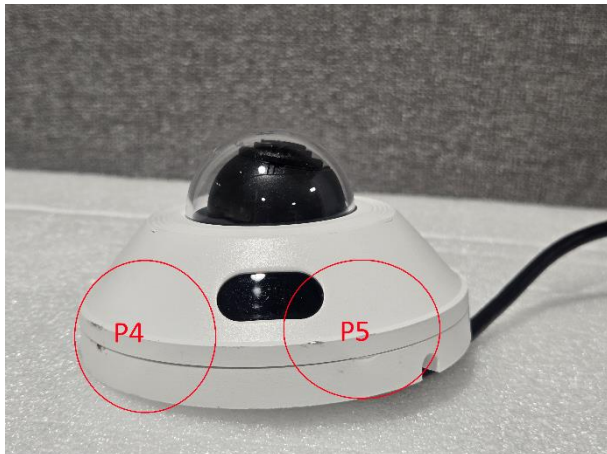

Check the hit area the test\_3



### CTK Co., Ltd.

5 Dongbu-ro 221beon-gil, Cheoin-gu, Yongin-si,  
Gyeonggi-do, Republic of Korea  
Tel: +82-31-339-9970  
Fax: +82-31-624-9501

REPORT No.:  
CTK-2026-00010  
Page (11) / (12) pages

### 3.5.2 Post-test product images



Top



Bottom



Front



Back



Left side



Right side



### CTK Co., Ltd.

5 Dongbu-ro 221beon-gil, Cheoin-gu, Yongin-si,  
Gyeonggi-do, Republic of Korea  
Tel: +82-31-339-9970  
Fax: +82-31-624-9501

REPORT No.:  
CTK-2026-00010  
Page (12) / (12) pages

## 3.6 Enclosure Dimensions or Impact point

### 3.6.1 Enclosure Dimensions (Unit: mm)

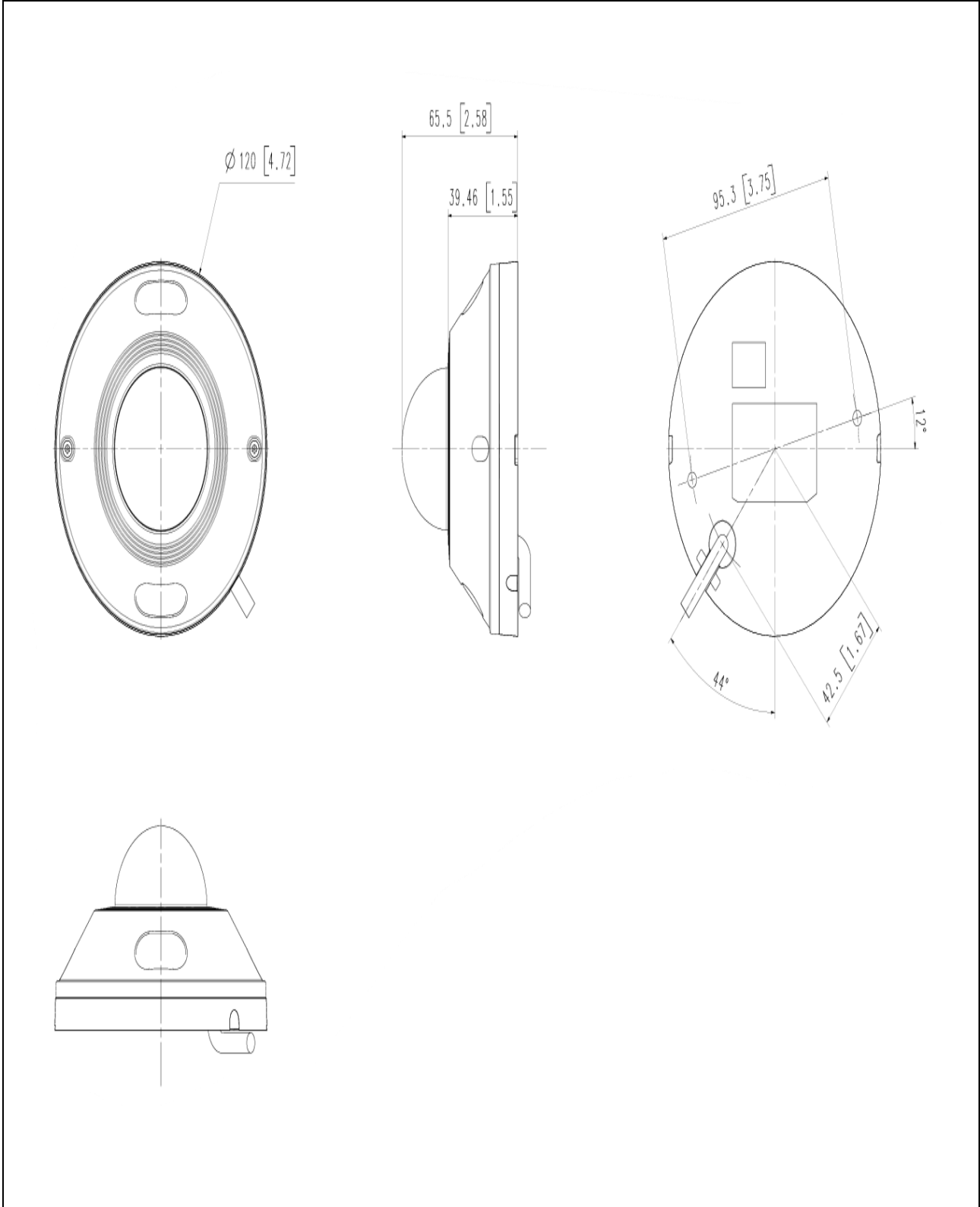

- End -