

Model No.	Name	Details
GV-Mount208-1	Swan Neck Mount 	Dimensions 1043 x 565 x 256 mm / 41.06 x 22.24 x 10.08" Weight 10.6 kg / 23.37 lb
GV-Mount208-2	Swan Neck Mount 	Dimensions 1043 x 519 x 256 mm / 41.06 x 20.43 x 10.08" Weight 10.5 kg / 23.15 lb
GV-Mount208-3 / 208-4	Swan Neck Mount 	Dimensions 1043 x 519 x 256 mm / 41.06 x 20.43 x 10.08" Weight 10.6 kg / 23.37 lb

- **GV-Mount208-2 unit: mm**

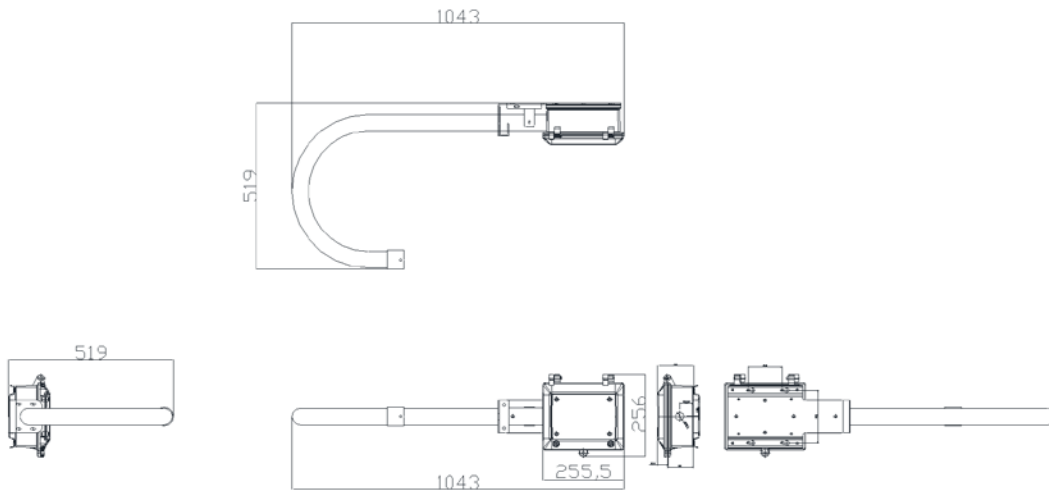

- **GV-Mount208-3 / 208-4 unit: mm**

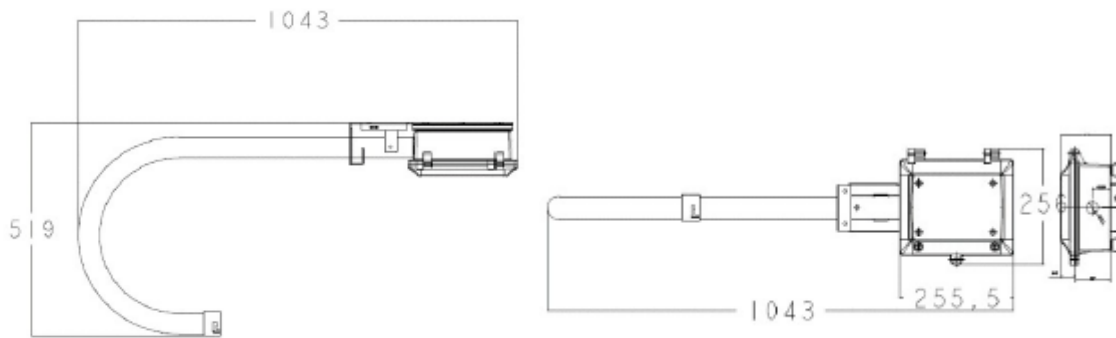

- **GV-Mount210 / 210-1 unit: mm**

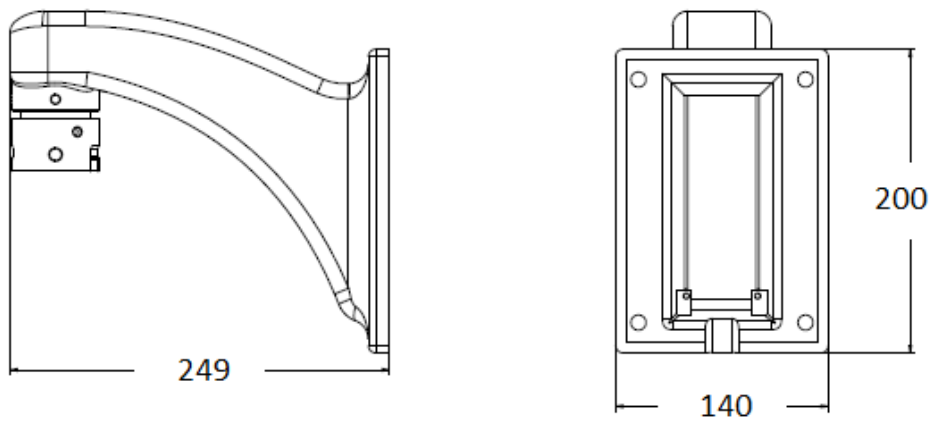

6.10.3 GV-SD2322-IR / GV-SD2722-IR / GV-SD3732-IR / GV-SD4825-IR / GV-SD4834-IR



GV-SD2322-IR / GV-SD2722-IR / GV-SD3732-IR

This installation method is only applicable to **GV-SD2322-IR / GV-SD2722-IR / GV-SD3732-IR / GV-SD4825-IR / GV-SD4834-IR**.

Required accessories:

- GV-Mount208-3

The user needs to prepare:

- Screws for ceiling x 4
- Corrugated tube x 1 (3/4", \varnothing 26.0 ~ 26.5 mm)



- Adjustable wrench x 1

Optionally extend with:

- GV-Mount702
-

6 Installing the GV-IP Speed Dome

1. To insert the SD card into the camera, see steps 1 and 2 in 6.1.3 *GV-SD2322-IR / GV-SD2722-IR / GV-SD3732-IR / GV-SD4825-IR / GV-SD4834-IR / GV-QSD5730-Outdoor / GV-QSD5731-IR*.
2. To install GV-Mount208-3 to the wall, follow steps 1 to 10 in 6.10.1 *GV-SD220-S / GV-SD2300*.
3. Attach the anti-drop safety ring (GV-Mount208-3, No. 9) to the tube connector (GV-Mount208-3, No. 8).
4. Secure the tube connector (GV-Mount208-3, No. 8) to the swan neck stainless tube.



5. Attach the safety lock of the camera to the anti-drop safety ring.



6. Thread the wires and cables through the tube. To connect the network, power and other cables to the camera, see *Connecting the Camera* section, *GV-IP Speed Dome User's Manual*.
7. Attach the camera onto the tube connector, rotate the camera until it is locked into position



8. Insert and tighten the indicated screws (GV-Mount208-3, No. 2).



9. Secure the junction box cover.

